

**Modular Cooking Range Line
 thermaline 90 - 14 lt Well Freestanding
 Gas Deep Fat Fryer, 1 Side, Backsplash,
 H=800**

ITEM # _____

MODEL # _____

NAME # _____

SIS # _____

AIA # _____



589507 (MCFHFBDPO) 14lt gas Deep Fat Fryer, one-side operated with backsplash

Short Form Specification

Item No. _____

Unit constructed according to DIN 18860_2 with 20 mm drop nose top and 70 mm recessed plinth. Internal frame for heavy duty sturdiness in stainless steel. 2 mm top in 1.4301 (AISI 304). Flat surface construction, easily cleanable. THERMODUL connection system enables seamless worktop when units are connected and avoids soil penetrating. Appliance designed to deep fry meat, fish and vegetables (french fries). Deep drawn V-shaped well with thermostatic regulation of oil temperature up to a maximum of 185 °C. Electrical ignition powered by battery with thermocouple for added safety. Flame failure device on each burner, with safety thermostat and thermostatic control. Reduced power setting to melt solid fat. Oil can be easily drained via a ball-valve. All-round basin raised edges to protect against soil infiltration. Large overflow stamped area around the well. Overheat protection switches off the supply in case of overheating. Metal knobs with embedded hygienic silicon "soft" grip enable easier handling and cleaning. IPX4 water resistant certification. Configuration: Freestanding, One-side operated with backsplash.

Main Features

- THERMODUL connection system creates a seamless work top when units are connected to each other thus avoiding soil penetrating vital components and facilitating the removal of units in case of replacement or service.
- Metal knobs with embedded hygienic "soft-touch" grip for easier handling and cleaning. The special design of the controls prevents infiltration of liquids or soil into vital components.
- Large visible digital display manufactured in tempered glass to resist heat and chemicals, showing temperatures or power settings. The display also shows on/off status of the appliance and on/off status of the heating elements.
- Raised edge all around the well to protect from infiltration of dirt from worktop.
- Electrical ignition powered by battery with thermocouple for added safety.
- Overheat protection: the temperature sensor switches off the supply in case of overheating.
- Indirect oil heating system and uniform heat distribution to guarantee extended oil life.
- Large overflow stamped area, located around the well.
- External heating elements allow to easily clean the well.
- Flame failure device on each burner.
- Deep drawn V-Shaped well.
- Thermostatic regulation of oil temperature up to a maximum of 185 °C.
- Safety thermostat and thermostatic control.
- All major components may be easily accessed from the front.
- Reduced power setting to melt solid fat.
- Oil level mark for MAX/MIN filling.
- Designed for deep fat frying of meat, fish, specialities and vegetable (french fries, chips).
- Oil can be drained off via a ball-valve with a lock to prevent unintentional opening. When opened, the ball valve provides a full cross-section opening to easily clean the drainage system.

Construction

- 2 mm top in 1.4301 (AISI 304).
- Unit constructed according to DIN 18860_2 with 20 mm drop nose top and 70 mm recessed plinth.
- Flat surface construction with minimal hidden areas to easily clean all surfaces
- IPx4 water protection.
- Internal frame for heavy duty sturdiness in stainless steel.

APPROVAL: _____

Front

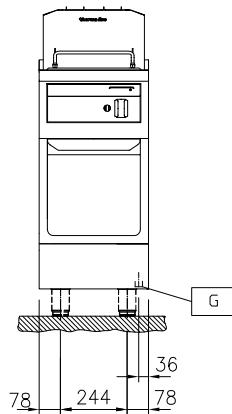

Side

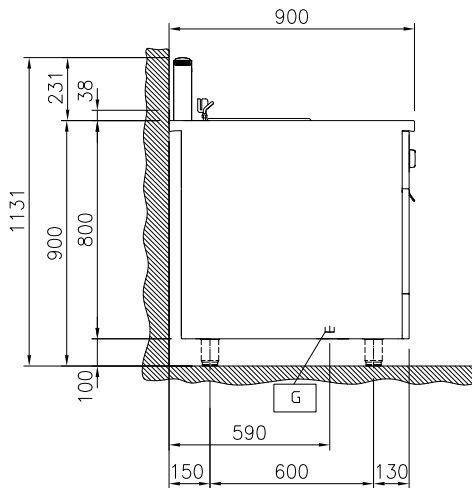

EQ = Equipotential screw
 G = Gas connection

Top

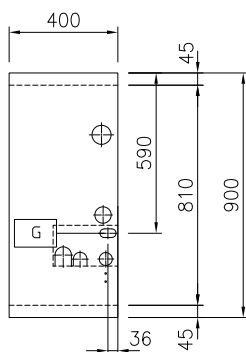
Gas

Gas Power:	14 kW
Gas Type Option:	
Gas Inlet:	1/2"

Key Information:

Number of wells:	1
Usable well dimensions (width):	240 mm
Usable well dimensions (height):	225 mm
Usable well dimensions (depth):	380 mm
Well capacity:	12 lt MIN; 14 lt MAX
Thermostat Range:	120 °C MIN; 190 °C MAX
External dimensions, Width:	400 mm
External dimensions, Depth:	900 mm
External dimensions, Height:	800 mm
Net weight:	85 kg
Configuration:	On Base; One-Side Operated

Included Accessories
Optional Accessories

- Discharge vessel for 14 & 23lt fryers PNC 911570
- Lid for discharge vessel 14 & 23lt fryers PNC 911585
- Connecting rail kit for appliances with backsplash, 900mm PNC 912499
- Portioning shelf, 400mm width PNC 912522
- Portioning shelf, 400mm width PNC 912552
- Folding shelf, 300x900mm PNC 912581
- Folding shelf, 400x900mm PNC 912582
- Fixed side shelf, 200x900mm PNC 912589
- Fixed side shelf, 300x900mm PNC 912590
- Fixed side shelf, 400x900mm PNC 912591
- Stainless steel front kicking strip, 400mm width PNC 912594
- Stainless steel side kicking strips left and right, against the wall, 900mm width PNC 912624
- Stainless steel side kicking strips left and right, back-to-back, 1810mm width PNC 912627
- Stainless steel plinth, against wall, 400mm width PNC 912897
- Stainless steel plinth, freestanding, 400mm width PNC 912916
- Connecting rail kit for appliances with backsplash: modular 90 (on the left) to ProThermetic tilting (on the right), ProThermetic stationary (on the left) to ProThermetic tilting (on the right) PNC 912981
- Connecting rail kit for appliances with backsplash: modular 90 (on the right) to ProThermetic tilting (on the left), ProThermetic stationary (on the right) to ProThermetic tilting (on the left) PNC 912982
- Back panel, 400x800mm, for units with backsplash PNC 913022
- Stainless steel panel, 900x800mm, against wall, left side PNC 913102
- Stainless steel panel, 900x800mm, against wall, right side PNC 913106
- Endrail kit, flush-fitting, with backsplash, left PNC 913117
- Endrail kit, flush-fitting, with backsplash, right PNC 913118
- Filter for deep fat fryer oil collection basin PNC 913146
- Endrail kit (12.5mm) for thermaline 90 units with backsplash, left PNC 913208
- Endrail kit (12.5mm) for thermaline 90 units with backsplash, right PNC 913209

- U-clamping rail for back-to-back installations with backsplash (to be ordered as S-code) PNC 913226
- Insert profile d=900 PNC 913232
- Side reinforced panel only in combination with side shelf, for against the wall installations, left PNC 913268
- Side reinforced panel only in combination with side shelf, for against the wall installations, right PNC 913270
- Stainless steel dividing panel, 900x800mm, (it should only be used between Electrolux Professional thermaline Modular 90 and thermaline C90) PNC 913673
- Stainless steel side panel, 900x800mm, flush-fitting (it should only be used against the wall, against a niche and in between Electrolux Professional thermaline and ProThermetic appliances and external appliances - provided that these have at least the same dimensions) PNC 913689
- Gas mainswitch for modular H800 gas units (factory fitted) PNC 913698